

# **DBK5772**

## **FULL SIZE FORD STOCK HEIGHT DISC BRAKE KIT**

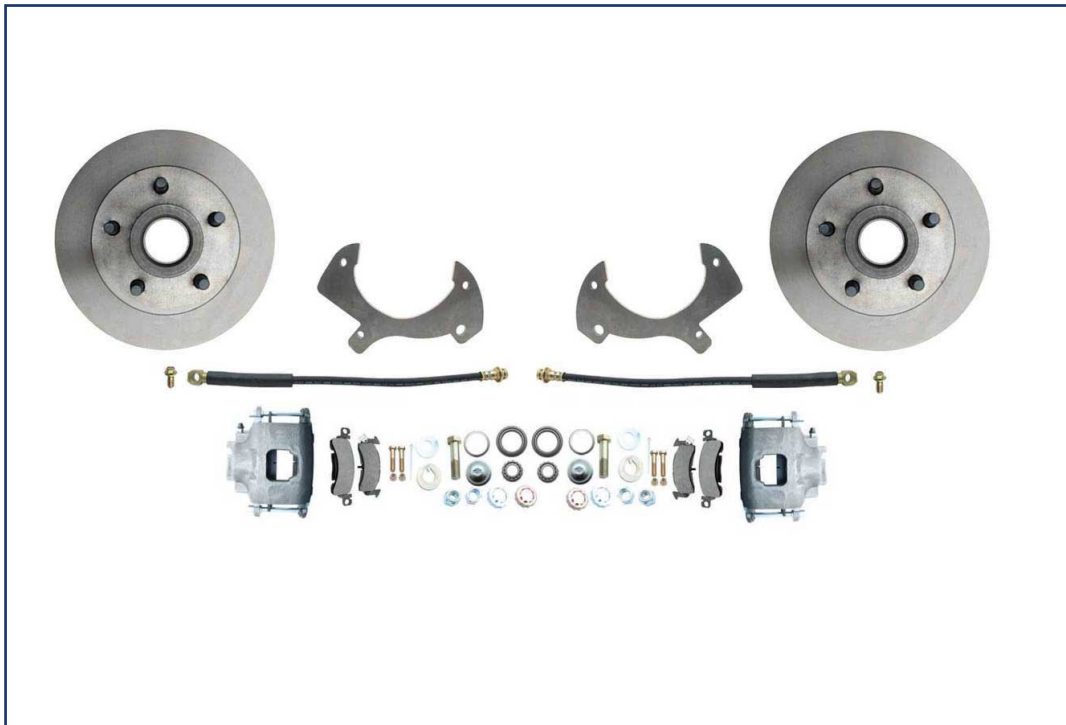

## **INSTALLATION INSTRUCTIONS**

**NOTE: ALWAYS REFER TO THE VEHICLE OWNER'S MANUAL FOR CORRECT TORQUE SPECIFICATIONS WHEN INSTALLING KIT.**

**WARNING** Proper operation of your brakes is essential for your safety and the safety of others. Any brake service should be performed **ONLY** by persons experienced in the installation and proper operation of brake systems. It is the responsibility of the person installing any brake component or kit to determine the suitability of the component or kit for the particular application. After installation, and before operating your vehicle, be sure to test the function of the brakes under controlled conditions. **DO NOT DRIVE WITH UNTESTED BRAKES!**

**IMPORTANT** Take time to read all the literature that came with this kit. Before beginning installation check the provided list of parts against what you received to ensure that all parts are present. While this kit was designed to make the process of changing brake parts as simple as possible, **NOTE: WITH SOME KITS IT MAY BE NECESSARY TO MAKE MINOR CHANGES TO YOUR CAR! READ ALL WARRANTY DISCLAIMERS AND RETURN POLICIES INCLUDED IN THIS KIT PRIOR TO INSTALLATION!**

**NOTE** Always utilize safely restraints when operating the vehicle. The installation of disc brakes will require the use of 15" wheels. Any attempt to install disc brake with a 14" wheel will be the customer's responsibility.

# INSTALLATION INSTRUCTIONS

<b>PARTS INCLUDED WITH THIS KIT:</b>		
<b>PART #</b>	<b>DESCRIPTION</b>	<b>QUANTITY</b>
FSFD	Caliper Bracket	2
5405	Rotors	2
HWK5772	Hardware Kit	1
A12	Inner Bearings	2
A13	Outer Bearings	2
A2	Outer Bearing	2
A6	Inner Bearings	2
6815	Seals	2
20618101MBM	Dust Caps	2
4045-4046	Calipers	2
<b>PERFORMANCE UPGRADE PARTS:</b>		
5405	Standard Rotors	2
HSDBKSS-10mm	Stainless steel braided hoses	2
<b>OPTIONAL PARTS (NOT INCLUDED WITH KIT, AVAILABLE FOR SEPERATE PURCHASE):</b>		
	Power Booster	
	Master Cylinder	
	Proportioning Valve Kit	
	Vacuum Hose & Fittings	
	Firewall Bracket	

## **PREPARING YOUR VEHICLE TO INSTALL YOUR BRAKE SYSTEM UPGRADE**

1. Rack the vehicle.
2. If you don't have a rack, then you must take extra safety precautions.
3. Choose a firmly packed and level ground to jack up the vehicle.
4. Chock the rear wheels.
5. Jack the vehicle up and support it with jack stands and secure the pins.
6. Set the parking brake and put the transmission in park if automatic, reverse if manual transmission.
7. The front wheels should be allowed to free hang to relieve tension on the coil springs.

**IMPORTANT** NEVER rely on jacks to support a vehicle! Always test the steadiness of your stands that are supporting the vehicle before attempting to work on a raised vehicle!

## **DISSEMBLE THE FRONT ROTORS:**

1. Remove wheels and retain the lugs nuts for later use. Replace any that are damaged.
2. Remove the dust caps, the cotter pins, the nut cages, washers and spindle nuts, and attempt to remove the brake drum.
3. If the drum will not come off, remove the rubber cover from the backing plate and insert a narrow screwdriver or adjusting tool to relax the self-adjuster mechanisms. You may need to disengage the adjusting lever from the adjusting screw to be able to pull the brake drums over the shoes.
4. With the tool, retract the brake shoes so you can remove the brake drums, wheels bearings and grease seals.
5. Drain the brake fluid from the front circuit by loosening the wheel cylinder bleeder screws. Protect any painted surfaces with rags from brake fluid.
6. Carefully remove the metal brake lines from the rubber flex hoses and remove the hoses from their anchor mounts. Cover the ends of the brake lines with rags to protect painted surfaces.
7. Remove the brake shoes and the drum backing plates so all that remains are the factory drum spindles. For this kit, the factory spindles will be used so proceed to spindle preparation.



## **COMPONENTS TO INSPECT, REPLACE OR UPGRADE DURING INSTALLATION OF DISC CONVERSION KITS**

Tie rod ends and nuts	Adjustment sleeves	Control arm shafts, mounting bolts, & nuts
Control Arms	Idler arm and nut	Pitman Arm and nut
Upper Ball Joints and nuts	Lower Ball Joints and nuts	Shocks and hardware
Residual valves	Metering valves	Proportioning valves
Brake lines	Stainless steel brake lines	Stainless steel hardware

## **SUGGESTIONS:**

- » Take the time to identify any suspect parts that are not included in this kit.
- » Consider making upgrades such as converting to polyurethane bushings, performance shocks, tubular a-arms, etc.
- » Plan any Installation (s) of replacement parts during the various stages of the drum to disc conversion process.

## INSTALLATION OF THE DISC BRAKE KIT REQUIRES THE USE OF THE FOLLOWING TOOLS & CHEMICALS:

Wheel bearing seal driver	Drum brake tool	Flare wrench set	Wheel chocks
3/8" ratchet drive set	3/8" Allen wrench or socket	Jack stands	Brake spring pliers
Box end wrench set	Ball joint fork	Tire iron	Brake bleeder wrench
Pliers	Screwdriver	Snips	Grease gun
Universal Bearing Packer	Line bending tool	Disc brake quiet	Wheel bearing grease
Ball pein hammer	Disc brake pad spreader tool	Brake Fluid	Brake cleaner
Caliper slide grease	Hand cleaner		

### SPINDLE PREPERATION

1. Use brake cleaner to clean the spindles thoroughly.
2. Inspect the spindles for any signs of stress cracks or damage that would make them unfit for continued service. Inspect the outer tie rod ends and the steering arm through holes. Inspect the ball joints and their mounting holes in the spindles for excessive play. Replace tie rods, ball joints or spindles if necessary.
3. There are several key areas that require special attention. Perform each of the following steps:
  - A. Inspect the bearing landings on the arbors of the spindles. The shafts should be free of nicks and burrs
  - B. Inspect and clean out the threads of the hole on the top of the spindle that secured the drum backing plate. These thread will be re-used and must be good. Re-tap them if necessary.
  - C. Light grinding will be necessary to mount the lower mounting tab of the caliper bracket on the rear of the spindle. The caliper bracket mounts on the spindle in the position that has the caliper directly over the steering arms. So on the side with the integrated steering arm lightly grind the contact area. (FIG 1)

### MOUNT THE CALIPER BRACKET

1. Test fit the caliper bracket on the spindle. The caliper bracket mounts on opposite faces of the spindle (figure 2). The top of the bracket mounts on the shaft side of the spindle and the squared tab mounts to the rear side over the through hole next to the steering arm. Again, the bracket should rest flush against both mounting surfaces on the spindle. If it does not mount flush, grind the rear mounting tab section adjacent to the steering arm until it mounts flush. You may need to do a little chamfering on the bracket first. Then if necessary, you might have to do a little bit of grinding in that same area on the back of the stub. It's not hard, but just needs to be trial fitted a couple of times. Just remove some metal along the length of this straight bit. (FIG 2)
2. Proceed to mounting the rotor. Once bracket install is complete. (FIG 3)



FIG1.



FIG2.



FIG3.

## MOUNT THE ROTOR

1. In the various Ford vehicles there were two different spindle shaft sizes used and we provide both bearing sizes and spindle washers in this kit. You will be discarding one of the two sets and their spindle washers.
2. To determine which bearing set to use, (1965 & Up requires larger bearing) measure the diameter of the inner bearing location on the spindle arbor to see if it is 1.250" or 1.375" (FIG 4). **If it measures 1.250", you will be using the A2 (LM 11949) and A6 (LM 67048) bearings. If it measures 1.375", you will be using the A12 (LM 12749) and A13 (L68149) bearings.**
3. The rotors provided in this kit already have races inserted in them. But if you determined you will be using the A2 and A6 bearings, you will need to remove the races in the 5405 rotor. In other words, the larger diameter spindle shafts require you to change the races in the rotor provided. **To do this, use a punch to tap out the old races and use a bearing and race driver to install the races from A2 and A6. The race number for A2 is LM11910, and the race number for A6 is L67010.**
4. Inspect the rollers of the bearings and verify they spin freely. Test fit the bearings on both spindles to make sure the install with ease before final assembly.
5. Use a bearing packing tool to thoroughly grease each bearing prior to installation with high temp, high quality wheel bearing grease.
6. With the correct races installed in the rotor, insert the greased inner bearing into the rotor.
7. Next tap the grease seal in flush using the bearing driver tool or a wooden block. The lip must face inward towards the hub.
8. With inner bearing and seal installed, put the rotor on to the spindle shaft.
9. Pack more wheel bearing grease the inside hub of the rotor by hand until the hub is completely filled.
10. Install the greased outer bearing, the appropriate sized keyed washer, the spindle nut, and the spindle nut cage.
11. With the wheel rotating, torque the spindle nut to 17 to 25 Ft. lbs.
12. Back off ½ turn. Spin rotor again and torque again to 10 to 15 in lbs.
13. Install the cotter pin and bend the tips to secure it.
14. Verify the rotors spin freely.
15. Proceed to mounting the calipers.



FIG 4.

## MOUNTING THE CALIPER

1. Remove the caliper mounting bolts from their sleeves and coat them with caliper slide grease.
2. Remove the brake pads from the calipers and put disc brake quiet on the back side of the pads. Next test fit your inner wheel bearing onto the spindle. (See preparing your parts)
3. As the disc brake quiet becomes tacky, mount the pads back into the caliper. Be sure to secure the pad clip to the interior pad. Pack the bearings and the rotors with grease if this has yet to be done.
4. Use pliers or a hammer to bend the mounting ears of the outer pads so they "grip" the caliper body and are secure and don't rattle.
5. Adjust the caliper bolt slide sleeves, and insert the caliper slide bolts back into position.
6. Install the calipers into the caliper bracket with the bleeder screws pointed up.

